

plasma brush[®] PB3 Integration

Operating instructions



Thank you for buying a high-quality **relyon plasma** GmbH branded product.
To get the best from your machine, please read these instructions carefully.

i Important!
Read these instructions carefully before assembling, installing and starting up the machine!

Always follow the safety instructions! Failure to follow the safety instructions may result in accidents, serious injury and serious damage to the machine.

The plasmabrush PB3 Integration may only be started up and operated by trained and qualified persons!

Train your staff! The operator/user is responsible for ensuring that personnel have fully understood the operation of the machine and the safety requirements.

© Copyright **relyon plasma** GmbH 2021.

All rights reserved. All rights reserved.

Text, images and graphics as well as their layout are protected by copyright and other protective laws. Unauthorised copying and distribution of this document and the utilisation and communication of its contents are strictly prohibited unless expressly authorised. Offenders will be held liable for the payment of damages. All rights reserved in the event of the grant of a patent, utility model or design.

Translation of the original
operating instructions

1	Safety	4
1.1	Residual risks.....	4
1.2	Information and obligations for the operator	6
1.3	Intended use	6
1.4	Impermissible operating conditions.....	6
1.5	Emissions	6
2	Description of the machine	7
2.1	Function.....	7
2.2	Machine overview.....	7
2.2.1	Entire machine	7
2.2.2	Stand-alone unit: Description and connections.....	8
2.2.3	Remote control (available as an option): Description	9
2.2.4	Plasma generator: Description.....	10
2.2.5	Pin assignment of PLC interface.....	11
2.3	Scope of delivery.....	12
3	Technical data	12
3.1	Technical data.....	12
3.2	Permissible operating parameters	13
4	Transport/Storage	14
4.1	Storage	14
4.2	Transport	14
5	Unpacking and installation	14
5.1	Unpacking.....	14
5.2	Installation.....	15
6	Special notes on using the plasma process	17
6.1	General description	17
6.2	Notes on the correct handling of the substrates to be treated.....	18
6.3	Carrying out surface treatment	18
6.4	Measures to take after the surface treatment	18
7	Operation	19
7.1	Controls/Displays	19
7.2	Switching on and operating the machine.....	20
7.3	Switching off the machine.....	22
8	Taking out of service	23
9	Cleaning and maintenance	23
9.1	Cleaning.....	23
9.2	Maintenance for the stand-alone unit.....	23
9.3	Maintenance for the plasma generator.....	25
	Replacing nozzles and electrodes	25
10	Troubleshooting	27
10.1	Overview of faults/errors.....	27
10.2	Customer service	27
11	Environment	28
11.1	Disposal.....	28
12	Conformity/Standards	28
12.1	CE	28
12.2	Product standards	28
13	Spare and wear parts	29

1 Safety

The machine was designed in accordance with the relevant international standards. However, as with any technical product, hazards may arise if the system is not used properly or is used for purposes other than its intended use.

Working with the machine can be dangerous and may result in serious or fatal injury. It is therefore essential to protect yourself and others.

In addition to the safety instructions in this document, you must also comply with general safety standards.



Caution – Danger!

When working with the machine, please note and observe the safety instructions and requirements in these operating instructions because non-compliance may result in serious or fatal injury.

1.1 Residual risks

This machine has been manufactured in accordance with the current state of the art. However, it is impossible to eliminate residual risks.

Always adhere to the following safety instructions:



Caution – Electrical voltage!

- Danger from high voltage
 - Never direct the plasma beam at people or animals.
 - Never touch the plasma nozzle or the plasma jet when the machine is in operation.
 - Never touch the workpiece to be treated or its holder during plasma generation.
 - Make sure that no third party comes into contact with the workpiece to be treated or its holder.
 - If electrically conductive materials touch the workpiece to be treated, these materials must be earthed.

- Danger from 230 V
 - Do not start up the machine if damage is visible on the electrical connection, mains cable or machine itself. Replace the damaged parts or have them repaired by a qualified person.
 - The machine must be earthed.
 - Only connect the device to a power socket with earthing pins.
 - Make sure that the electrical data on the rating plate corresponds to your electricity supply.



Caution – Health hazard!

The machine operates at a high frequency (~ 40 to 65 kHz on the plasma generator).

- As a precaution, persons with a pacemaker, hearing aids or hearing implants should observe the following:
 - Do not use the machine in the vicinity of a pacemaker, hearing aids or hearing implants.
 - Seek medical advice before working near the system.
- In hospitals and similar facilities, it is possible that the operation of the system may impair the function of electrical medical equipment, computer equipment or other equipment (such as ECG systems or PCs).
 - Make sure that the operator of such equipment or systems is aware of this possibility before starting up the machine.



Caution – Hot surface!

The nozzle of the plasma generator may reach temperatures of up to 200 °C.

- Do not touch the nozzle during operation.
- If the nozzle or electrode need to be replaced, wait until the machine has cooled down.
- After operation, store the machine until it cools down in such a way that nobody is injured by the hot surfaces.
- After use, store the machine only in places that are not temperature-sensitive or are not combustible.



Caution – Nitrogen oxides and ozone (O₃)!

The machine may produce levels of nitrogen oxides and ozone that exceed current limits.

- Make sure that the working area is well ventilated.
- Install an extraction system.



Tripping hazard!

Position the machine in such a way that the cables do not present a tripping hazard.



Caution – Noise!

Depending on the particular use, the plasma generator may produce noise emissions, prolonged exposure to which may damage hearing.

- For prolonged use, wear suitable ear protection.
- Protect persons working in the vicinity of the machine.



Wear protective eyewear!

While working with the machine, particles from workpieces or other objects may be released into the air due to the gas that is emitted and the high temperatures that are reached.

- You absolutely must wear eye protection when working with the machine.
- Protect persons working in the vicinity of the machine.



Attention – Damage to machine!

The machine may overheat. Do not cover the ventilation slots.

1.2 Information and obligations for the operator

- The system may emit interference.
 - The system has been tested in accordance with EMC legislation.
 - The operator must verify and assure electromagnetic compatibility with other electrical and electronic equipment in the immediate vicinity of the system.
- Ensure that:
 - Operating personnel have read and understood these operating instructions.
 - Anyone working near the machine is made aware of the dangers and is provided with the necessary protective equipment.
 - Repairs are only carried out by qualified persons.
- In particular, make operating personnel aware of the safety instructions in this document.
- Always keep the system in a fully functional condition.
- Any modifications made to the machine will invalidate the operating licence and the warranty. Exception: if such modifications are expressly authorised by the manufacturer.

1.3 Intended use

The machine is intended solely for the plasma treatment of surfaces (e.g. metals, textiles, glass, plastics) to activate, clean, coat or remove residue at atmospheric pressure.

Under no circumstances may the machine be used by non-trained persons.

1.4 Impermissible operating conditions

The machine must not be operated under the following conditions:

- In explosive (Ex) zones
- In areas with a severe build-up of dust
- In environments where the humidity is too high (see technical data, page 12)
- At altitudes of more than 2000 m above sea level
- Where there are strong vibrations

1.5 Emissions

The connected plasma generator produces the following emissions:

- Small amounts of UV light
- Small amounts of ozone (O₃) and nitrogen oxides (NO_x) The workplace exposure limit (WEL) may be exceeded. Example:

Plasma gas	Gas flow	Ozone	NO _x
Air	35 l/min	1.5 mg/m ³	3500 mg/m ³



Note!

As a precautionary measure, we recommend using an extraction system with a capacity of at least 500 l per minute in the direct vicinity of the plasma outlet.

2 Description of the machine

2.1 Function

The machine is operated for the plasma treatment (activation, fine cleaning) of surfaces (metals, textiles, glass, plastics, ceramics and natural materials) at atmospheric pressure. This plasma treatment can produce significantly improved results during subsequent gluing, painting, printing, coating, wetting, laminating and metallising.

2.2 Machine overview

2.2.1 Entire machine

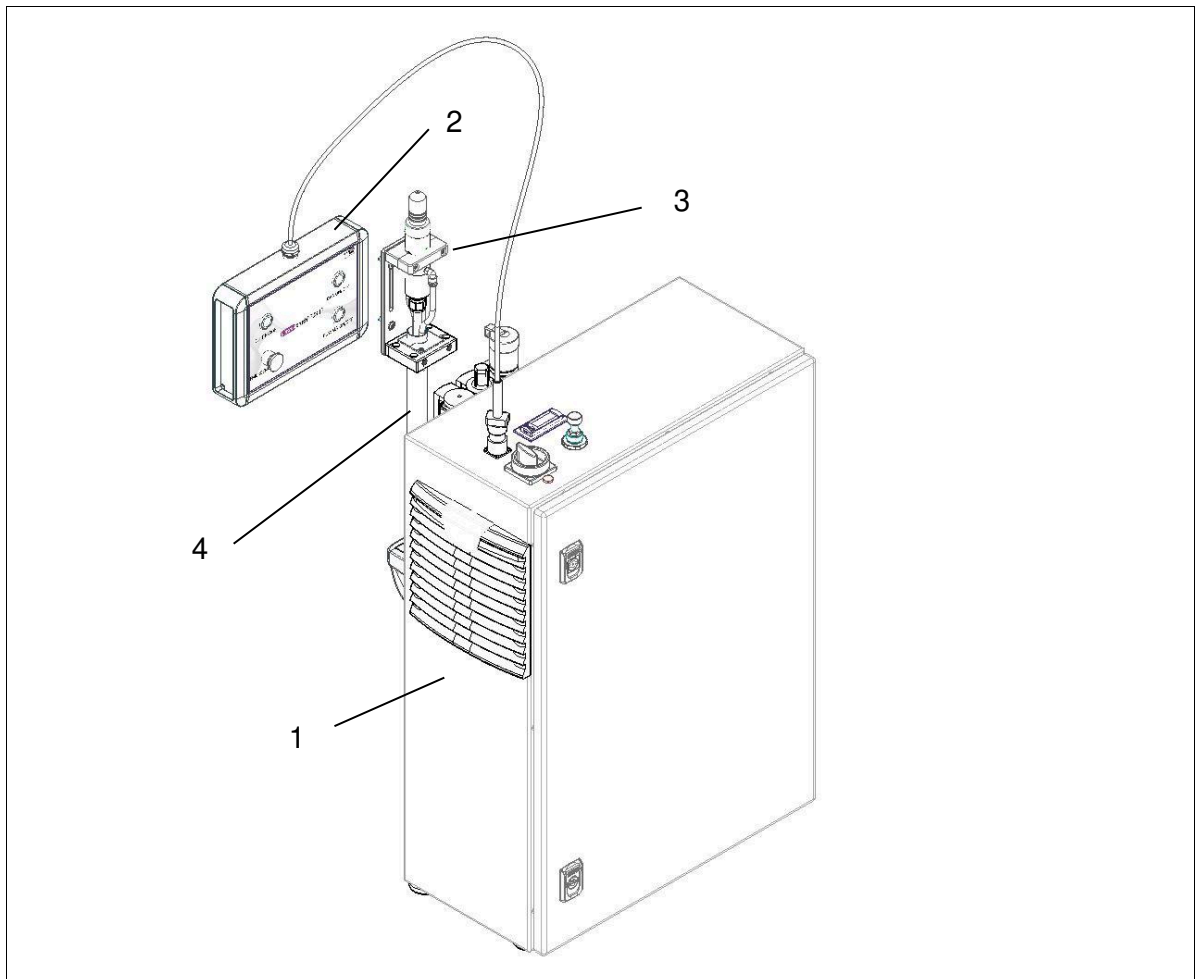

No.	Component
1	Stand-alone unit
2	Remote control (available as an option)
3	Plasma generator
4	Cable assembly incl. HV cable in black braided hose
5	Mains connection cable (not pictured)

2.2.2 Stand-alone unit: Description and connections

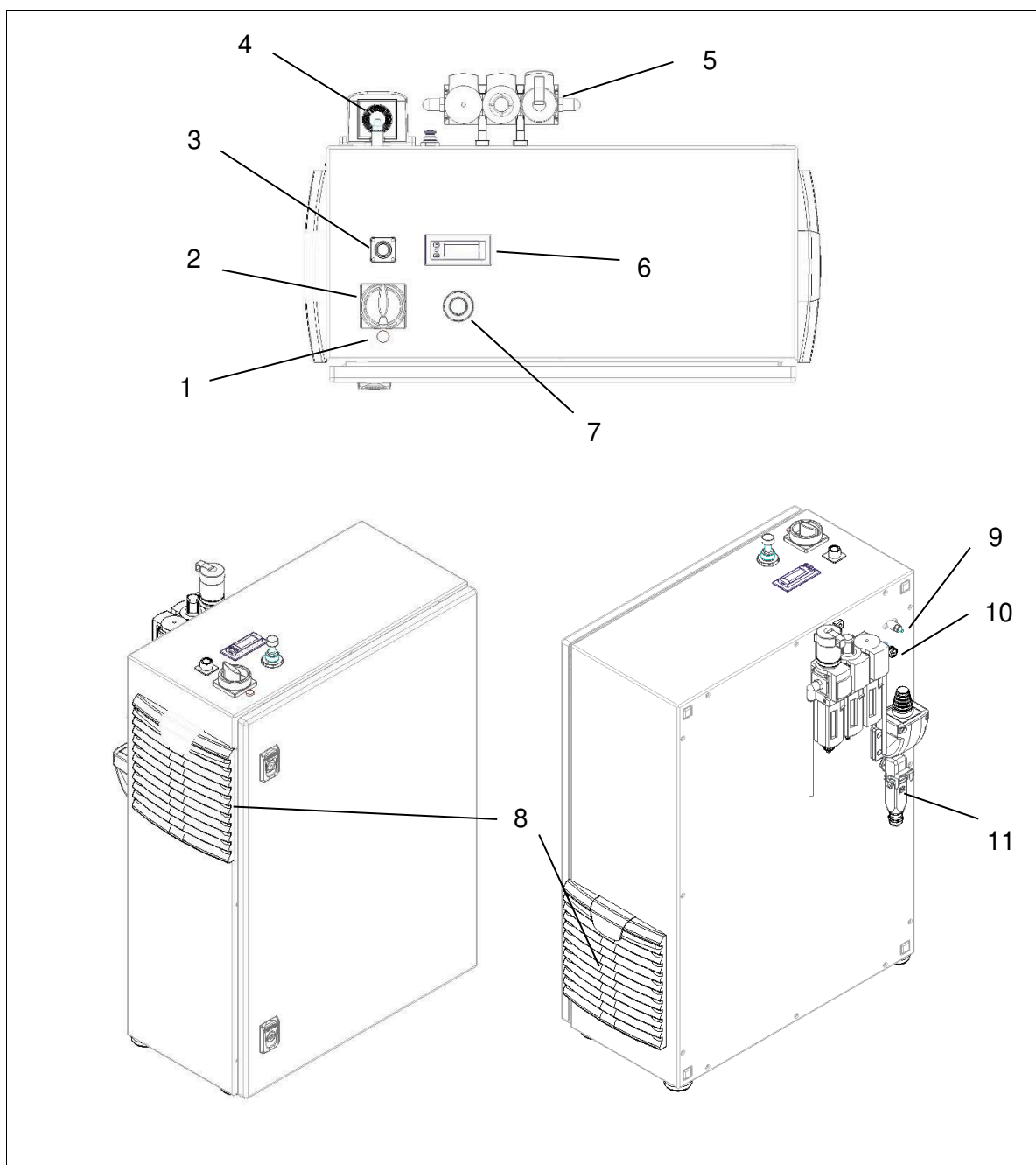

Fig.: Schematic diagram of the stand-alone unit (front view and top view)

No.	Component
1	Signal lamp for "machine on/off" (red)
2	Master switch I/O
3	Socket for remote control or PLC control
4	Cable assembly bushing (incl. HV cable)
5	Maintenance unit for compressed air supply
6	Flowmeter
7	Throttle valve for compressed air supply
8	Fan grille
9	Functional earth connection

10	Fuse F1 (see 3.1 Technical data)
11	Socket for mains connection cable (with cover cap)

2.2.3 Remote control (available as an option): Description

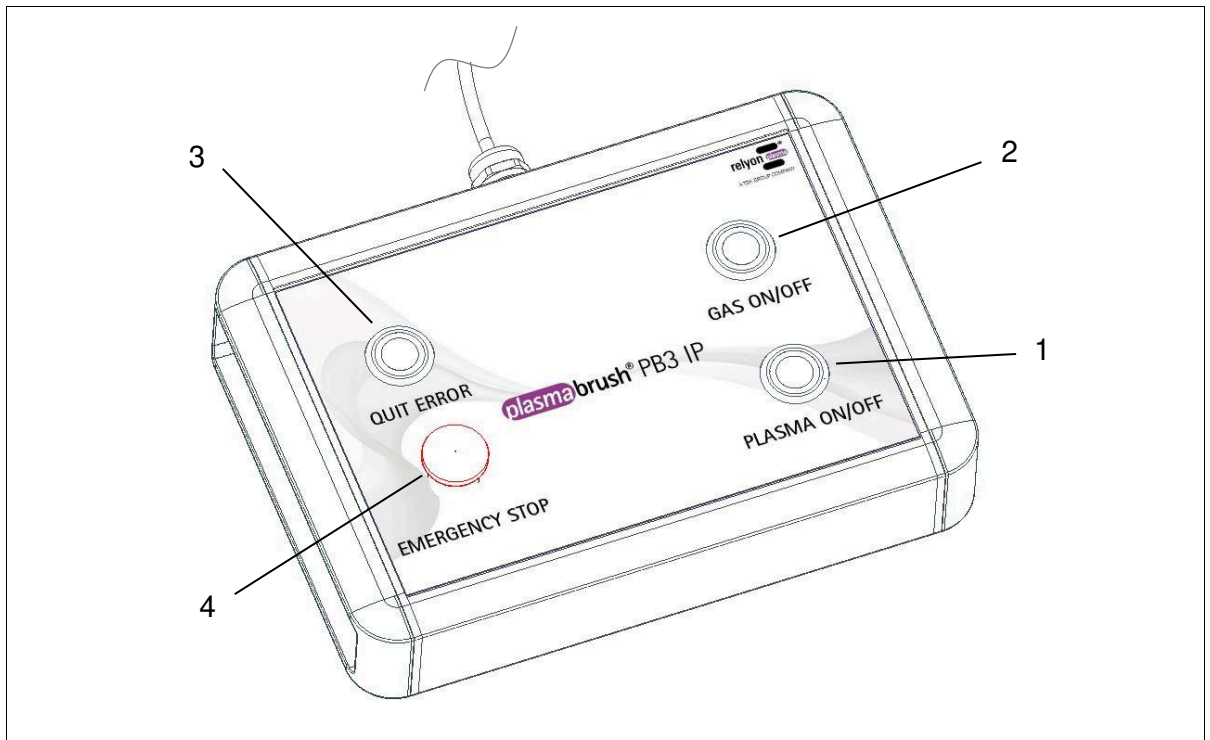

Fig.: Schematic diagram of the remote control

No.	Component
1	PLASMA ON/OFF switch
2	GAS ON/OFF switch
3	QUIT ERROR button
4	Emergency stop switch

2.2.4 Plasma generator: Description

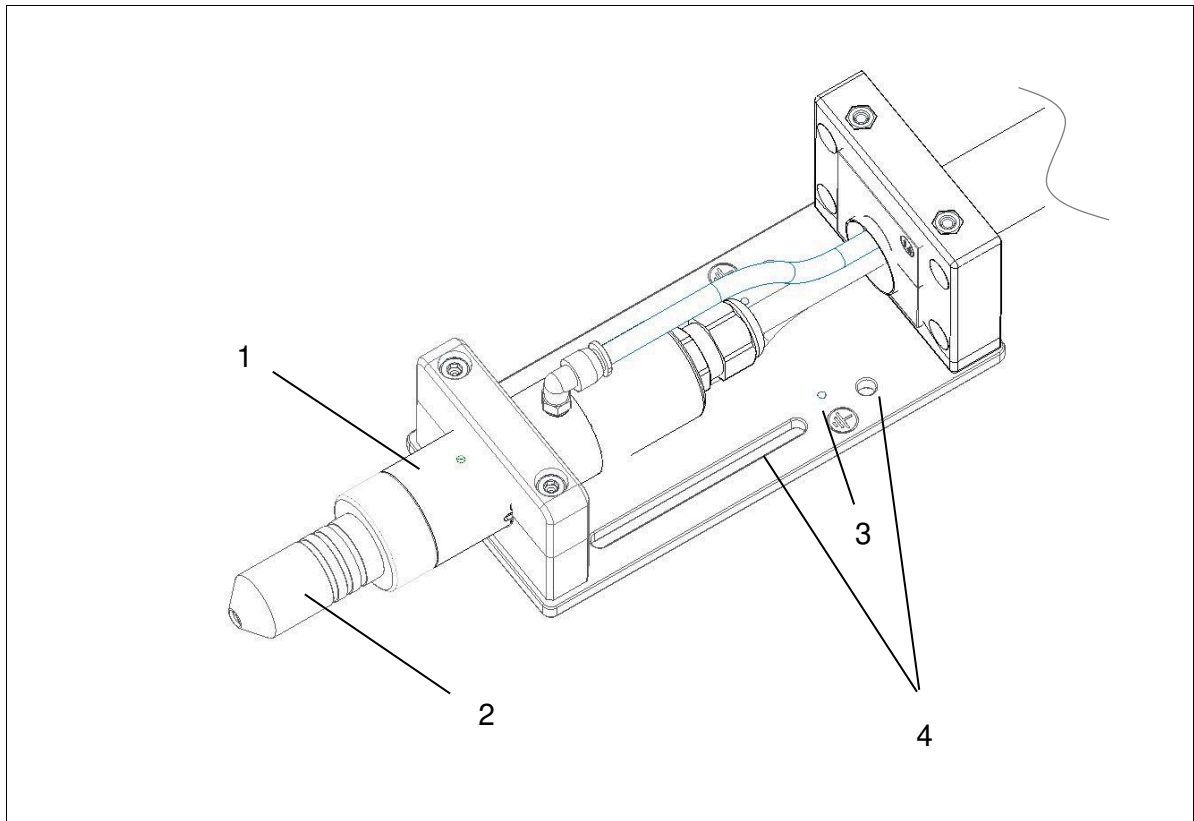

Fig.: Schematic diagram of the plasma generator

No.	Component
1	PB3 plasma generator PG-31
2	PB3 nozzle A450
3	M3 connection for PE cable
4	M5 mounting holes for attachment to customer unit



Attention – Damage to machine! Barrier sleeve made of ceramic in the plasma generator!

1. Ceramics sleeve and spacers, otherwise known as the barrier sleeves (not pictured), are inserted in the plasma generator (1).
2. The barrier sleeves are made of ceramic. Caution, risk of breakage.

2.2.5 Pin assignment of PLC interface

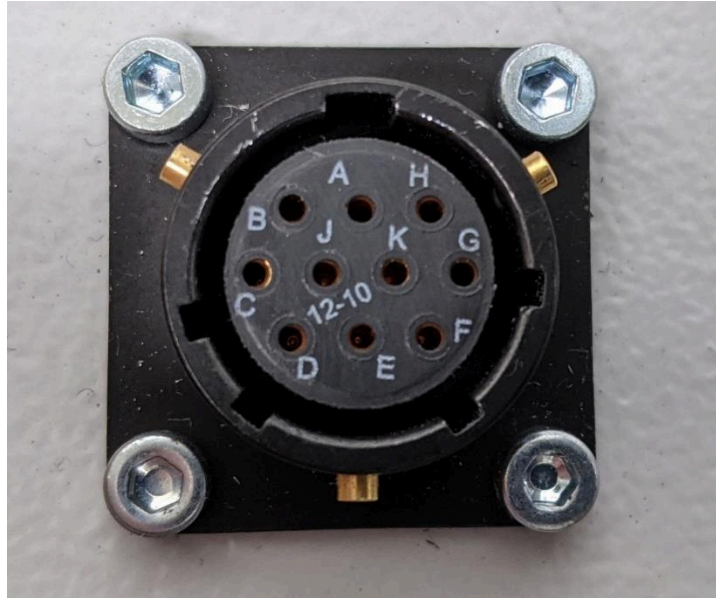

Fig.: Schematic diagram of the PLC interface

PIN socket	Colour of cable	Pin assignment
Input		
A	Pink	Enable "GAS ON/OFF"
C	Red	Enable "PLASMA ON/OFF"
E	Purple	Enable "QUIT ERROR"
G	Yellow	Emergency stop
Output		
K	Green	24 V DC power supply (24 V generated internally in the machine)
J	Black	GND
B	Blue	Feedback "GAS ON/OFF" (24 V/0 V)
D	White	Feedback "PLASMA ON/OFF" (24 V/0 V)
F	Brown	Feedback "QUIT ERROR" (24 V/0 V)
H	Grey	Emergency stop



Attention – Damage to machine!

For signal control (control via an external system) only use the 24 V power supply generated internally in the machine (PIN K). Do not feed an external 24 V power supply into the inputs of the machine (PIN A, C, E, G)!

2.3 Scope of delivery

The scope of delivery includes the following components:

- plasmabrush PB3 Integration machine (consisting of stand-alone unit and plasma generator, fixed on mounting plate)
- Optional: remote control
- Mains connection cable
- Operating instructions

3 Technical data

3.1 Technical data

Description	Value
Electrical data	
Electrical connection	220 V – 240 V AC / 50 Hz / max. 6 A
Mains fuse	F1 = 10 A / 250 V AC / time lag
Power consumption	≤ 1500 W
IP rating	Stand-alone unit: IP 54 Plasma generator: IP 20 (acc. to EN 60529) Remote control: IP 54
Protection class	Class I acc. to IEC 61140
Operating voltage of plasma generator	• up to 20 kV U_{peak} (max. voltage for ignition (briefly)) • up to 2 kV RMS (average operating voltage)
Activation period	100% (continuous mode)
Dimensions	
Weight	50 kg; 110.2 lbs
Dimensions	610 x 780 (1070) x 430 mm; 24.0 x 30.7 (42.1) x 16.9" (width x height x depth)
Cable assembly (incl. HV cable)	
Cable length	5 m
• Minimum cable bending radius	150 mm (5.9")
• Maximum cable extension torsion	± 90°/m
Operating conditions	
Air humidity	< 80% rel. (non-condensing)
Temperature	0 – 40 °C; 32 – 104 °F
Storage conditions	
Air humidity	< 80% rel. (non-condensing)
Temperature	0 – 60 °C; 32 – 140 °F
Noise emissions	
• Sound level	< 60 dB(A) at 1 metre away

Gas connection	
• Gas types	Compressed air (purified, free of oil and lubricants) Nitrogen (industrial gases free of particles and oil) Additional gas types only after approval from relyon plasma .
• Gas flow rate	40 – 80 l/min
• Quality	Compressed air 1.4.1 acc. to ISO 8573.1 Nitrogen 2.8 (N2) acc. to DIN EN ISO 14175:N1
• Connection	6 mm quick-release coupling

3.2 Permissible operating parameters

The specified limits or conditions must be observed during operation:

Description	Value
Gas flow	Air: $\geq 40 - \leq 80$ l/min Nitrogen: $\geq 40 - \leq 80$ l/min
Activation period	100% (continuous mode)
Plasma on	Before activating the high voltage for plasma generation, the gas supply to the plasma generator must be switched on for at least 2 seconds.



Caution – Electrical voltage!

- Danger from high voltage
 - Never reach into the plasma flame or onto the substrate to be treated during operation.
 - All components, workpieces or tools that come into contact with the plasma must be either insulated (dielectric strength > 30 kV) or fastened or held with a secure earth.



Attention – Damage to machine!

- The required gas flow rate is between 40 and 80 l/min and must not be fallen short of or exceeded.

Non-compliance will damage the plasma generator beyond repair.

4 Transport/Storage

4.1 Storage

- Store the machine in a dry place. This will prevent the electrical contacts from corroding.
- Protect the machine from dirt and foreign objects.
- Protect the plasma generator and gas connection from dirt and foreign bodies.

4.2 Transport

The machine is designed for stationary use in production. It is not intended to be moved to a different location on a regular basis. When transporting the machine, make sure that it is switched off, disconnected from the mains and cooled down.

Check that all moving parts are in a stable, fixed position so that they cannot fall off when moving the machine.

After transport is complete, make sure that the machine is placed in a stable and secure position in a suitable place.



Attention – Damage to machine!

- The machine can become damaged if you attempt to move the stand-alone unit by pulling on one of the cables. Always ensure that there is no nominal tensile stress on the cables. This also applies to the signal cable of the optional remote control.
The cable assembly (incl. HV cable) or signal cable can also be damaged by kinking or bending it too tightly. Do not kink the cable assembly or signal cable and adhere to the minimum permitted bending radii in accordance with the “Technical data” chapter (page 12).
- A ceramic component is built into the plasma generator. This can become damaged in the event of hard impacts or falls, and can in turn damage the machine. Always ensure that the plasma generator is secured against impacts and falls during transport.

5 Unpacking and installation



Caution – Electrical voltage!

Danger: 230 V and high voltage.

- The entire machine must not be opened. The stand-alone unit is sealed by the manufacturer. In the event of damage to the seal, the warranty is voided.

5.1 Unpacking

- Carefully open the machine packaging. Note the information about directions provided on the packaging.
- Take the machine out of the packaging.
- After taking the machine out of the packaging, check it and all cables for damage.

5.2 Installation

Before installing the machine, the following criteria must be met:

- The machine must be fully intact.
- The machine may only be connected using the power cable provided.
- The machine's main switch is to be used as an all-pole separator.
- A suitable gas supply (see Chapter 3.1 and 3.2) must be provided.

The stand-alone unit may only be operated while in an upright position. Ensure that there is sufficient clearance (> 150 mm) in front of the ventilation slots.

To install the machine, perform the following steps in the specified order:

1. Place the machine on a hard, level floor and make sure that the machine is stable.
 - Ensure that a clearance of at least 150 mm is maintained between all ventilation slots and other objects.
 - Make sure that the installation location is chosen such that no nominal tensile stress is placed on the cables and lines when using the machine.
2. Mount the plasma generator in your system using suitable M5 screws. Follow the drilling pattern of the mounting plate (see figure below) on which the generator is delivered. The screws for clamping the plasma generator and cable assembly (incl. HV cable) must not be loosened!
3. Connect a suitable 6 mm hose for supplying compressed air to the compressed air maintenance unit. Set the operating pressure to at least 4 bar.
4. Open the cover on the machine for the mains connection and connect the mains connection cable to the machine.
5. Plug the mains connection cable into a suitable power socket with earthing pins.

If in doubt, check if the protective earth contact of the power socket is functional.

- ✓ The machine is installed.



Attention – Damage to machine!

The stand-alone unit and plasma generator must be set up and fastened in a stable manner.

Always ensure that there is no nominal tensile stress on the cables.

Non-compliance will damage the machine and/or its components beyond repair!

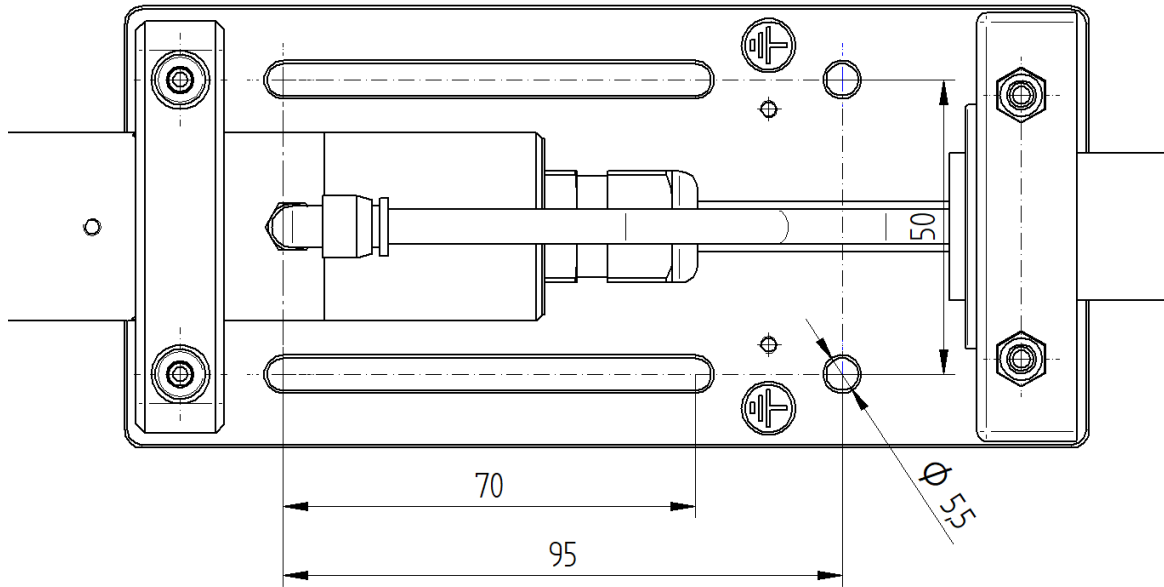

Fig.: Schematic diagram of the mounting plate

6 Special notes on using the plasma process

6.1 General description

Treating surfaces with atmospheric plasma has several advantages, such as increasing the surface energy to produce better surface wetting.

Optimum surface wetting is the first and often most decisive step to achieving a good imprint, a uniform coating, a consistent coat of lacquer or an integrally bonded adhesive application. The bond at this boundary layer often determines the longevity and adhesive strength of this material pairing.

Atmospheric-pressure plasma increases throughput in many industrial processes, while at the same time saving the costs of solvents or chemical primers. We have successfully integrated our plasma products into the following application fields:

- Fine cleaning of metal, glass and plastics
- Surface activation and surface functionalisation for optimised wettability
- Coating for new surface properties
- Plasma-assisted laminating processes
- Plasma-assisted adhesive bonded joints
- Plugging and sealing
- Plasma-induced reduction of metal surfaces
- Chemical-free bleaching of textiles
- Plasma sterilisation of fabric
- Treatment of food products to improve quality and shelf life
- Sterilisation of thermally unstable plastics
- Multi-component injection moulding

Practically all technical material classes can be efficiently processed under atmospheric pressure:

- Metals, metal alloys
- Plastics and composite materials
- Glass, ceramics, inorganic composites, natural stone
- Real leather, imitation leather
- Natural fibres, wood, paper

Since the plasma treatment is always just a single part of the entire process, it is important that the additional influencing variables are known in order to achieve an optimum result.

Typical influencing variables could be:

- Plasma process: distance to the substrate, speed, nozzle geometry
- Substrate/workpiece: material composition, contamination, electrical conductivity, thermal conductivity, moisture content
- Workpiece treatment: contamination before or after the plasma process, the time elapsed between the plasma process and the follow-up process

Treatment examples can be requested directly from **relyon plasma** GmbH.

Additional information on applications, as well as publications, can be found on the website at www.relyon-plasma.com.

6.2 Notes on the correct handling of the substrates to be treated



Caution – Electrical voltage!

- Danger from high voltage
 - Never direct the plasma beam at people or animals.
 - Never touch the plasma nozzle or the plasma jet when the machine is in operation.
 - Never touch the workpiece to be treated or its holder during plasma generation.
 - Make sure that no third party comes into contact with the workpiece to be treated or its holder.
 - If electrically conductive materials touch the workpiece to be treated, these materials must be earthed.

Since the machine operates with high voltage, certain safety precautions must be taken. This applies not only to direct handling of the machine, but also to the workpiece to be treated and its holder.

In general, the workpiece holder and all other objects that the workpiece comes into contact with must be earthed. There must be no chance whatsoever of the user or a third party making contact with the workpiece holder (made from conductive material), for example, during plasma treatment. It is also possible that a third party could receive an electric shock from the workpiece through the workpiece holder.

If a holder made from insulating material is used, it must have a dielectric strength of at least 20 kV.

A functional earth connection is provided on the machine for a special form of plasma treatment involving transferred electric arcs. If you want to use this special application, please contact **relyon plasma** GmbH directly.

6.3 Carrying out surface treatment

Depending on the type and condition of your substrate, pre-cleaning before the plasma process can improve the overall outcome.

The effect of the treatment depends on the working distance, treatment time, speed and consistency of movement, as well as the material to be treated.

Ensure that the substrate is not thermally damaged due to movement that is too slow or a working distance that is too close.

Treatment examples can be requested directly from **relyon plasma** GmbH.

6.4 Measures to take after the surface treatment

To achieve an optimum result, it is important that as little time as possible elapses after the plasma treatment and that the treated surface is not touched or contaminated. Cleaning the surface AFTER the plasma treatment is not recommended. Since the workpiece may heat up depending on the type and duration of the plasma process, it may be necessary to allow the workpiece to cool down first before the next process step is executed. This is to ensure that the process will not be negatively impacted by the introduction of heat (e.g. in certain bonding processes).



Caution – Hot surface!

The workpiece to be treated may be heated up by the plasma process, depending on the process parameters. If necessary, allow the workpiece to cool down before handling it.

7

Operation

7.1

Controls/Displays



Caution – Electrical voltage!

Danger of electric shock.

- Never reach into the area around the connected plasma generator while it is running or if it has shut down (e.g. to check why the plasma generator has shut down).

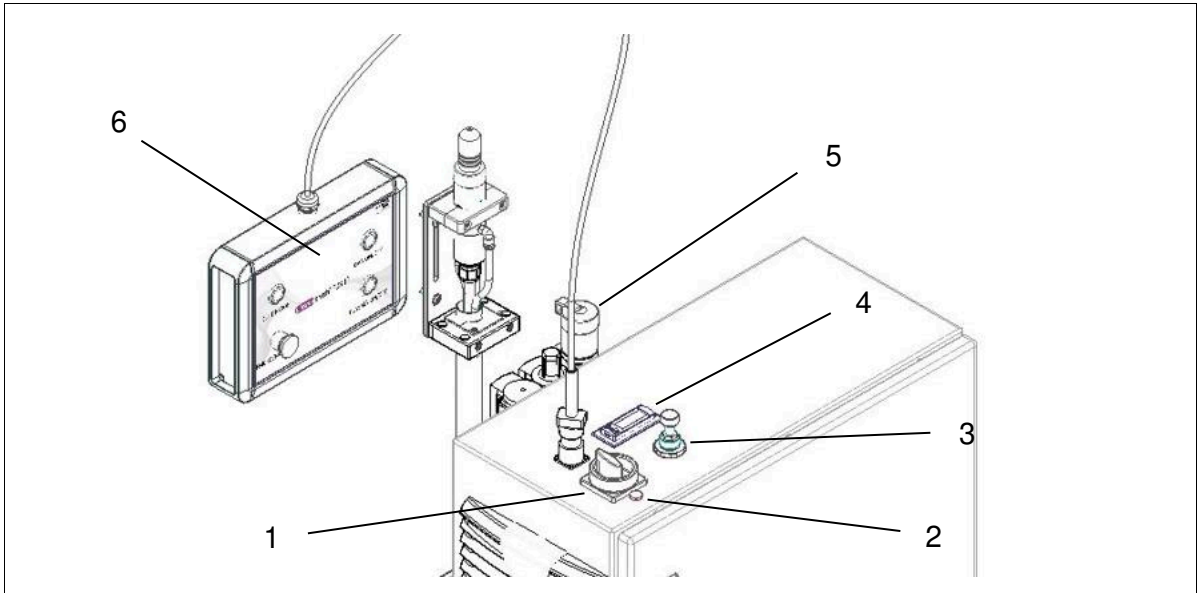

Fig.: Schematic diagram of the controls

No.	Description	Function
1	Master switch	Switches the power supply voltage on/off
2	“Power on” LED (red)	Indicates: power supply is established, master switch is switched on
3	Throttle valve for compressed air supply	Opens and regulates the compressed air supply to the plasma generator
4	Flowmeter	Indicates: - Illuminated blue: gas flow suitable for operation (40 – 80 l/min) - Illuminated red: gas flow not suitable for operation (< 40 l/min)
5	Maintenance unit for compressed air supply	Filters the supplied compressed air and regulates the supply pressure
6	Remote control (available as an option)	Operates the plasma generator



Attention – Damage to machine!

- The machine can become damaged if you attempt to move the stand-alone unit by pulling on one of the cables. Always ensure that there is no nominal tensile stress on the cables.
The cable assembly can also be damaged by kinking or bending it too tightly. Do not kink the cable assembly (incl. HV cable) and adhere to the minimum permitted bending radius in accordance with the “Technical Data” chapter (page 12).
- A ceramic component is built into the plasma generator. This can become damaged in the event of hard impacts or falls, and can in turn damage the machine. Always ensure that the plasma generator is secured against impacts and falls during transport.
- The plasma generator may be damaged if it is started without gas. Never switch on the plasma generator before the gas stream (2 seconds) is switched on.
- When switching off the plasma generator via the “Plasma ON/OFF” button, the gas supply must continue for at least 2 seconds. During this follow-on time, never switch off the machine at the master switch and do not disconnect the power supply. This could cause damage to the machine.

The machine can be operated as a stand-alone unit via the remote control or with a higher-level system control.

To switch the machine on, perform the following steps in the specified order:

1. Switch the machine on using the master switch (#1).
The lamp (#2) next to the machine's master switch lights up.
2. Connect a stable, external compressed air supply to the maintenance unit (#5) on the back of the machine. Set the pressure at the pressure gauge to at least 4 bar.
3. Operation with a higher-level system control: The solenoid valve must be unlocked to enable the gas flow. To do this, connect PIN K and PIN A (see 2.2.5). Set a suitable gas flow (40 – 80 l/min) at the throttle valve (#3); this will be audible from the nozzle.
Operation with an optional remote control: Press the “GAS ON/OFF” switch on the remote control (#6). This enables the gas flow to the plasma generator or interrupts it if pressed again. Set a suitable gas flow (40 – 80 l/min) at the throttle valve (#3); this will be audible from the nozzle. If the flow is suitable, the display lights up blue and the “GAS ON/OFF” switch on the remote control lights up green. If the gas flow is insufficient, the display on the flowmeter (#4) lights up red.
4. Operation with a higher-level system control: Once the gas flow has been established, the plasma process can be started. To start the plasma process, connect PIN K and PIN C (see 2.2.5). To end the plasma process, disconnect PIN K and PIN C. Note the gas follow-on time of 2 seconds. During this time, the machine must not be switched off or disconnected from the mains under any circumstances!
Operation with an optional remote control: To start the plasma process, press the “PLASMA ON/OFF” switch on the remote control (#6). The switch lights up blue and plasma is generated visibly and audibly at the nozzle of the plasma generator. To stop the plasma process, press the “PLASMA ON/OFF” switch on the remote control again. Note the gas follow-on time of 2 seconds. During this time, the machine must not be switched off or disconnected from the mains under any circumstances!

5. Operation with a higher-level system control: PIN G and PIN H must be disconnected for the emergency stop functionality (see 2.2.5). This stops the plasma process. After making sure that safe operation is possible, unlock the machine by connecting PIN G and PIN H. To acknowledge the triggered emergency stop, PIN K and PIN E must be connected. Also make sure that PIN K and PIN C are disconnected (no plasma process).

Operation with an optional remote control: In emergencies, both the plasma process and the gas supply are interrupted by pressing the emergency stop switch on the remote control (#6). After making sure that safe operation is possible, the emergency stop switch must be released by turning it clockwise and the error must be acknowledged by pressing the “QUIT ERROR” button on the remote control. The “PLASMA ON/OFF” switch must also be released. For further plasma processes, steps 3 and 4 must be repeated.

- ✓ The machine is switched on.

**Caution – Hot surface!**

The area around the plasma generator nozzle may reach temperatures of up to 200 °C.

- Wait until the machine has cooled down if you need to touch this area.
- After use, store the machine only in places that are not temperature-sensitive or are not combustible.

To switch off, perform the following steps in the specified order:

1. Operation with a higher-level system control: To stop the plasma process, disconnect PIN K and PIN C (see 2.2.5). Note the gas follow-on time of 2 seconds. During this time, the machine must not be switched off or disconnected from the mains under any circumstances!
Operation with an optional remote control: To stop the plasma process, press the “PLASMA ON/OFF” switch on the remote control. Note the follow-on time of 2 seconds. During this time, the machine must not be switched off or disconnected from the mains under any circumstances!
 2. Operation with a higher-level system control: The solenoid valve must be closed to interrupt the gas flow. To do this, disconnect PIN K and PIN A. After that, no more hissing can be heard at the nozzle.
Operation with an optional remote control: Press the “GAS ON/OFF” switch on the remote control (#6). This interrupts the gas flow to the plasma generator. After that, no more hissing can be heard at the nozzle.
 3. Fully close the throttle valve for compressed air supply (#3).
 4. Close the pressure gauge on the maintenance unit for compressed air supply (#5).
 5. Switch off the stand-alone unit by toggling the master switch (#1) to position “O”.
- ✓ The machine is switched off.

**Attention – Damage to machine!**

Do not switch off the system while gas is still flowing (2 seconds).

The gas follow-on time must have elapsed completely before the entire system is switched off, otherwise the plasma generator may overheat even if it is already switched off.

8 Taking out of service

To take the machine out of service, perform the following steps in the specified order:

1. Switch the machine off using the master switch (#1).
 2. Disconnect the machine from the mains voltage supply: disconnect the power connector.
 3. Close the mains connection socket on the stand-alone unit with the cover cap.
 4. Disconnect the compressed air supply hose from the maintenance unit for compressed air supply (#5).
- ✓ The machine is out of service.

9 Cleaning and maintenance



Caution – High voltage! Danger of death!

High voltage is produced in the interior of the machine. This voltage is still present after the machine is switched off.

- It is forbidden to open the machine.
- Before carrying out maintenance, servicing or repair work, always disconnect the machine from the power supply.



Attention – Damage to machine!

Opening the machine may cause it to be damaged.

- It is forbidden to open the machine.

9.1 Cleaning

Only clean the outside of the machine.

- The machine must be cooled down, switched off and disconnected from the mains voltage supply.
- Only clean the machine with a damp cloth.

9.2 Maintenance for the stand-alone unit

Replace the filter mats at least every 2000 operating hours. If working in environments with high levels of dust, they may have to be replaced sooner. You can source the filter mats needed as spare parts from

relyon plasma GmbH.

To change the dust filters, proceed as follows:

1. Disconnect the power supply from the machine.
2. Open the filter holder by the tab with the logo.



3. Insert a new filter mat.

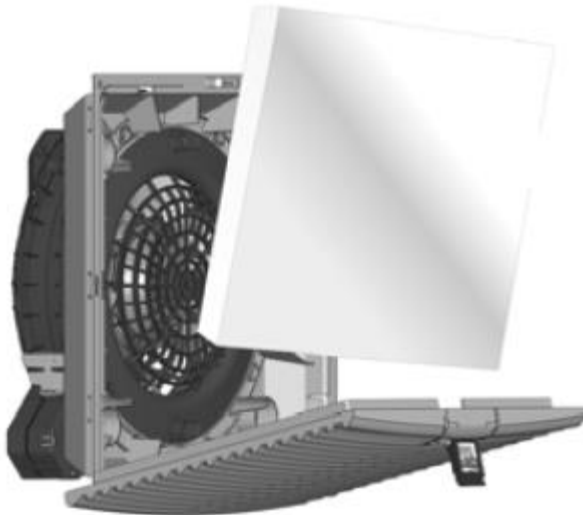

4. Press the filter holder closed by the tab until it noticeably clicks into place.

9.3 Maintenance for the plasma generator



Caution – Hot surface!

The area around the plasma generator nozzle may reach temperatures of up to 200 °C.

- Wait until the machine has cooled down if you need to touch this area.
- After use, store the machine only in places that are not temperature-sensitive or are not combustible.



Attention – Damage to machine!

The cap nut is designed for tightening and loosening by hand. Do not use a tool to tighten or loosen the cap nut. This may damage the machine.

The plasma generator contains the plasma nozzle and the inner electrode. These are subject to wear and tear depending on the duration of use, the environmental conditions and the process that was carried out.

A thick oxide layer on the plasma nozzle and a marked burnt-in crater on the electrode will impair the ignition properties and increase the temperature of the plasma flame. In these cases the parts must be replaced.

Replacing nozzles and electrodes

The replacement cycles of the nozzles and electrodes have been determined by relyon plasma in accordance with a standardised test. Deviations are possible, depending on application.

- Nozzles in operation with air: approx. 500 hours
- Electrodes in operation with air: approx. 1000 hours

Depending on application, considerable deviations are possible from these average values.



Attention – Damage to machine!

Disconnecting certain screw connections can damage the plasma generator beyond repair.

- Please refer to the information in the operating and maintenance instructions for the nozzle set.
- Never loosen screw connections that are not expressly required for replacing nozzles and electrodes.

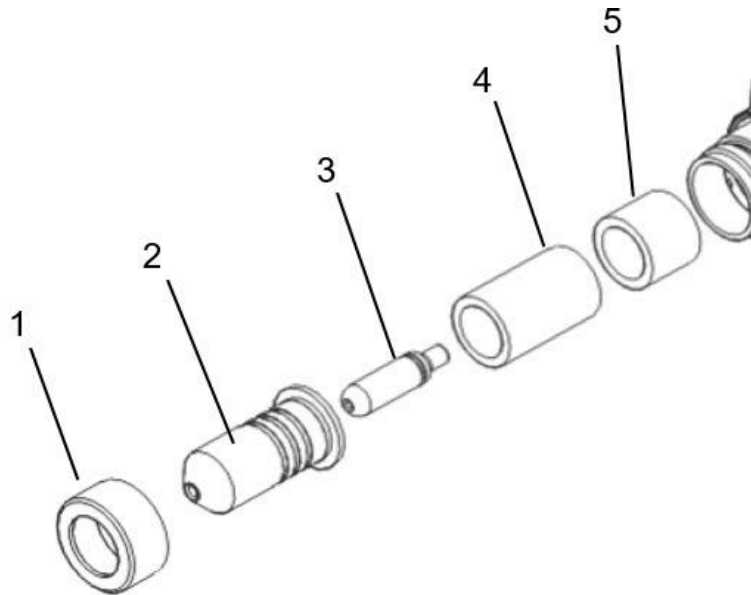

To replace the nozzle and electrode, perform the following steps:

1. Switch off the machine and wait until the plasma generator has cooled down.
 2. Unscrew the nozzle (2) with the cap nut (1) (right-handed thread).
Caution: When removing the nozzle, the ceramic sleeve (4) and the spacer for the ceramic sleeve can fall out of the generator housing (5)!
 3. Unscrew the electrode with O-ring (3) (right-handed thread) using an Allen key (width a/f 2.5 mm).
 4. Extract the electrode with O-ring (3) out of the coil by hand.
 5. Insert the new electrode with O-ring (3) by turning it into the coil and screw it in tightly with a torque wrench (tightening torque 1 Nm).
 6. If necessary, first install the spacer for the ceramic sleeve (plastic), then install the ceramic sleeve (4) back into the generator housing (5).
Caution: Observe the correct sequence during installation!
 7. Screw the new nozzle (2) with the cap nut (1) to the generator housing (5) again and tighten it hand-tight.
- ✓ The nozzle and electrode are now replaced.

i

Attention: Barrier sleeve made of ceramic in the plasma generator!

1. Barrier sleeves (#4 and #5) are inserted in the plasma generator.
2. Ensure that these barrier sleeves are inserted in the correct sequence. Absent or incorrectly inserted barrier sleeves cause the plasma generator to be damaged beyond repair.
3. The barrier sleeve (#4) is made of ceramic. Caution, risk of breakage!

10 Troubleshooting

10.1 Overview of faults/errors

Fault/Error	Cause	Rectification
Master switch (#1) does not light up.	Fuse defective.	Fuse on the rear side of the machine must be changed.
	Power connector incorrectly connected.	Check the mains unit connection.
	No/incorrect voltage supply.	Check the mains voltage supply.
No plasma is being generated.	There is an error, the machine is not ready.	Make sure that the emergency stop switch is released and the error has been acknowledged. Make sure that the Plasma ON/OFF switch is released.
	There is an internal error.	De-energise the machine. Switch on again.
	No communication between HMI and machine.	Make sure that the remote control/PLC control is connected to the machine.
	Gas flow not present or insufficient.	Make sure that the gas supply is properly connected to the machine and that there are no leaks/damage to the hoses. Specified range $\geq 40 - \leq 80$ l/min.
	Wear of nozzle or electrode.	Check wear of nozzle and electrode, replace if necessary
	Short circuit, the plasma generator is defective.	Contact customer service.
	Cable breakage.	Check the cable from the power supply to the plasma generator for possible cable breakage or kinks.
	Problem cannot be fixed.	Contact customer service.
Parasitic discharge (discharge at undesired points, e.g. at plasma generator cable connector).	Machine or high-voltage cable damaged.	Take the machine out of service and contact customer service.
Damage from flashover (e.g. to machine parts).	Faulty earth connection.	Check that all earth connections have been established correctly.

10.2 Customer service

If the machine is not working properly, contact **relyon plasma** GmbH.

You will find the contact information at the end of the operating instructions.

11 Environment

11.1 Disposal



Be mindful of the environment.

Used electrical and electronic equipment must not be disposed of along with normal waste.

- The machine contains valuable materials that can be recycled. Take the machine to a suitable collection point.

12 Conformity/Standards

12.1 CE



We declare that this product conforms to CE standards.

The product name can be found on the rating plate on the machine housing.

12.2 Product standards

The machine satisfies the following requirements and standards:

2014/30/EU EC EMC Directive Directive 2014/30/EU of the European Parliament and of the Council of 26 February 2014 on the harmonisation of the laws of the Member States relating to electromagnetic compatibility	
2014/35/EU EC Low Voltage Directive Directive 2014/35/EU of the European Parliament and of the Council of 26 February 2014 on the harmonisation of the laws of the Member States relating to the making available on the market of electrical equipment designed for use within certain voltage limits	
EN 61000-6-4:2019+A1:2011 emissions	
EN 61000-6-2 2019 immunity	
EN 61000-3-2:2019 and EN:61000-3-3:2013 emissions	
EN 61010-1:2010 safety test	
EN 63000:2018 restriction of hazardous substances (RoHS)	
Degree of protection IP 20 or IP 54	IEC 60529

13 Spare and wear parts

Item number	Description	Type
77071600	Spacer for ceramic sleeve	Spare part
74532300	Ceramic sleeve	Spare part
77071900	Cap nut	Spare part
76849401	PB3 electrode with O-ring	Wear part
1000242500	A250 nozzle	Wear part
1000600700	A350 nozzle	Wear part
78707200	A450 nozzle	Wear part

relyon plasma GmbH
A TDK Group Company

Osterhofener Straße 6
93055 Regensburg
Germany

Phone: +49-941-60098-0
Fax: +49-941-60098-100
E-mail: info@relyon-plasma.com
<http://www.relyon-plasma.com>