

plasma tool

Operating instructions



Thank you for buying a high-quality **Relyon Plasma** GmbH branded product.
To get the best from your machine, please read these instructions carefully.

i **Important!**
Read these instructions carefully before assembling, installing and starting up the machine!

Always follow the safety instructions! Failure to follow the safety instructions may result in accidents, serious injury and serious damage to the machine.

The plasma tool may only be started up and operated by trained and qualified persons!

Train your staff! The operator/user is responsible for ensuring that personnel have fully understood the operation of the machine and the safety requirements.

© Copyright **Relyon Plasma** GmbH 2017.

All rights reserved.

Text, images and graphics as well as their layout are protected by copyright and other protective laws. Unauthorised copying and distribution of this document and the utilisation and communication of its contents are strictly prohibited unless expressly authorised. Offenders will be held liable for the payment of damages. All rights reserved in the event of the grant of a patent, utility model or design.

Original operating
instructions

1	Safety	4
1.1	Residual risks.....	4
1.2	Information and obligations for the operator	6
1.3	Intended use	6
1.4	Impermissible operating conditions.....	6
1.5	Emissions.....	6
2	Description of machine	7
2.1	Function	7
2.2	Machine overview	7
2.2.1	Entire machine.....	7
2.2.2	Stand-alone unit: Description and connections	8
2.2.3	Handheld device: Description	9
2.3	Scope of delivery.....	9
3	Technical data	10
3.1	Technical data.....	10
4	Transport/storage	11
4.1	Storage.....	11
4.2	Transport.....	11
5	Unpacking and installation	13
5.1	Unpacking	13
5.2	Installation requirements.....	13
5.2.1	Installation and start-up	13
5.2.2	Using the spacer	13
6	Special note on the operation of the plasma process	16
6.1	General description.....	16
6.2	Notes on the correct handling of the substrates to be treated	17
6.3	Carrying out surface treatment	17
6.4	Measures to take after the surface treatment	17
7	Operation	18
7.1	Controls / displays.....	18
7.2	Switching on and operating the machine	19
7.3	Switching off the machine	20
8	Taking out of service	20
9	Cleaning and maintenance	21
9.1	Cleaning	21
9.2	Maintenance for the stand-alone unit.....	22
9.3	Maintenance for the hand part	23
9.3.1	Replacing nozzles and electrodes.....	23
10	Troubleshooting	25
10.1	Overview of faults / errors	25
10.2	Customer service	25
11	Environment	26
11.1	Disposal	26
12	Conformity / standards	26
12.1	CE	26
12.2	Product standards	26
13	Spare and wear parts	27

1 Safety

The machine was designed in accordance with the relevant international standards. However, as with any technical product, hazards may arise if the system is not used properly or is used for purposes other than its intended use.

Working with the device can be dangerous and may result in serious or fatal injury. It is therefore essential to protect yourself and others.

In addition to the safety instructions in this document, you must also comply with general safety standards.



Caution - Danger!

When working with the machine, please note and observe the safety instructions and requirements in these operating instructions because non-compliance may result in serious or fatal injury.

1.1 Residual risks

This machine has been manufactured in accordance with the current state of the art. However, it is impossible to eliminate residual risks.

Always adhere to the following safety instructions:



Caution – electrical voltage!

- Danger from high voltage
 - Never direct the plasma beam at people or animals.
 - Never touch the plasma nozzle or the plasma jet when the machine is in operation.
 - Never touch the workpiece to be treated or its holder during plasma generation.
 - Make sure that no third party comes into contact with the workpiece to be treated or its holder.
 - If electrically conductive materials touch the workpiece to be worked on, these materials must be grounded.
- Danger from 230 V.
 - Do not start up the machine if damage is visible on the electrical connection, mains cable or machine: Replace the damaged parts or have them repaired by a qualified person.
 - The machine must be fully grounded.
 - Only connect the device to a grounded wall socket.
 - Make sure that the electrical data corresponds to the data rating plate of your electricity supply.



Caution – Health hazard!

The machine operates at a high frequency (~ 40 - 65 kHz in plasma generator).

- As a precaution, persons with a pacemaker, hearing aids or hearing implants should observe the following:
 - Do not use the machine in the vicinity of a pacemaker, hearing aids or hearing implants.
 - Seek medical advice before working near the system.
- In hospitals and similar facilities, it is possible that the operation of the system may impair the function of electrical medical equipment, computer equipment, or other equipment (such as ECG systems or PCs).
 - Make sure that the operator of such equipment or systems is aware of this possibility before starting up the machine.



Caution – Hot surface!

The nozzle of the plasma generator may reach temperatures of up to 200 °C.

- Do not touch the nozzle during operation.
- If the nozzle or electrode must be replaced, wait until the machine has cooled down.
- After operation, store the machine until it cools down in such a way that nobody is injured by the hot surfaces.
- After use, store the machine only in places that are not temperature-sensitive or are not combustible.



Caution – Nitrogen oxides and ozone (O₃)!

The machine may produce levels of nitrogen oxides and ozone that exceed current limits.

- Make sure the working area is well ventilated.
- Install an extraction system.



Tripping hazard!

Position the machine in such a way that the cables do not present a tripping hazard.



Caution – Noise!

Depending on the particular use, the plasma generator may produce noise emissions, prolonged exposure to which may damage hearing.

- For prolonged use, wear suitable ear protection.
- Protect persons working in the vicinity of the machine.



Wear protective eyewear!

While working with the machine, particles from workpieces or other objects can be let into the air through emitted gas or the occurring temperatures.

- You absolutely must wear eye protection when working with the machine.
- Protect persons working in the vicinity of the machine.



Attention – damage to machine!

The machine may overheat. Do not cover the ventilation slots.

1.2 Information and obligations for the operator

- The system may emit interference.
 - The system has been tested in accordance with EMC legislation.
 - The operator must verify and assure electromagnetic compatibility with other electrical and electronic equipment in the immediate vicinity of the system.
- Ensure that:
 - Operating personnel have read and understood these operating instructions.
 - Anyone working near the machine is made aware of the dangers and is provided with the necessary protective equipment.
 - Repairs are only carried out by qualified persons.
- In particular, make operating personnel aware of the safety instructions in this document.
- Always keep the system in fully functional condition.
- Any modifications made to the machine will invalidate the operating licence and the warranty. Exception: Such modifications are expressly authorised by the manufacturer.

1.3 Intended use

The machine is intended solely for the plasma treatment of surfaces (e.g. metals, textiles, glass, plastics) to activate, clean, coat or remove residue at atmospheric pressure. Under no circumstances may the machine be used by non-trained persons.

1.4 Impermissible operating conditions

The machine must not be operated under the following conditions:

- In explosive (Ex) zones
- In areas with severe build-up of dust
- In environments where the humidity is too high (see technical data, page 10)
- At altitudes of more than 2,000 m above sea level
- Where there are strong vibrations

1.5 Emissions

The connected plasma generator produces the following emissions:

- Small amounts of UV light
- Small amounts of ozone (O₃) and nitrogen oxide (NO_x) The workplace limit value may be exceeded. Example:

Plasma gas	Gas flow	Ozone	NO _x
Air	35 l/min	1.5 mg/m ³	3500 mg/m ³



Note!

As a precautionary measure, we recommend using an extraction system with a capacity of at least 500 l per minute in the direct vicinity of the plasma outlet.

2 Description of machine

2.1 Function

The machine is operated for the plasma treatment (activation, cleaning) of material surfaces (metals, textiles, glass, plastics) at atmospheric pressure. This plasma treatment can produce significantly improved results during subsequent gluing, painting, printing, coating, wetting, laminating and metallising.

2.2 Machine overview

2.2.1 Entire machine

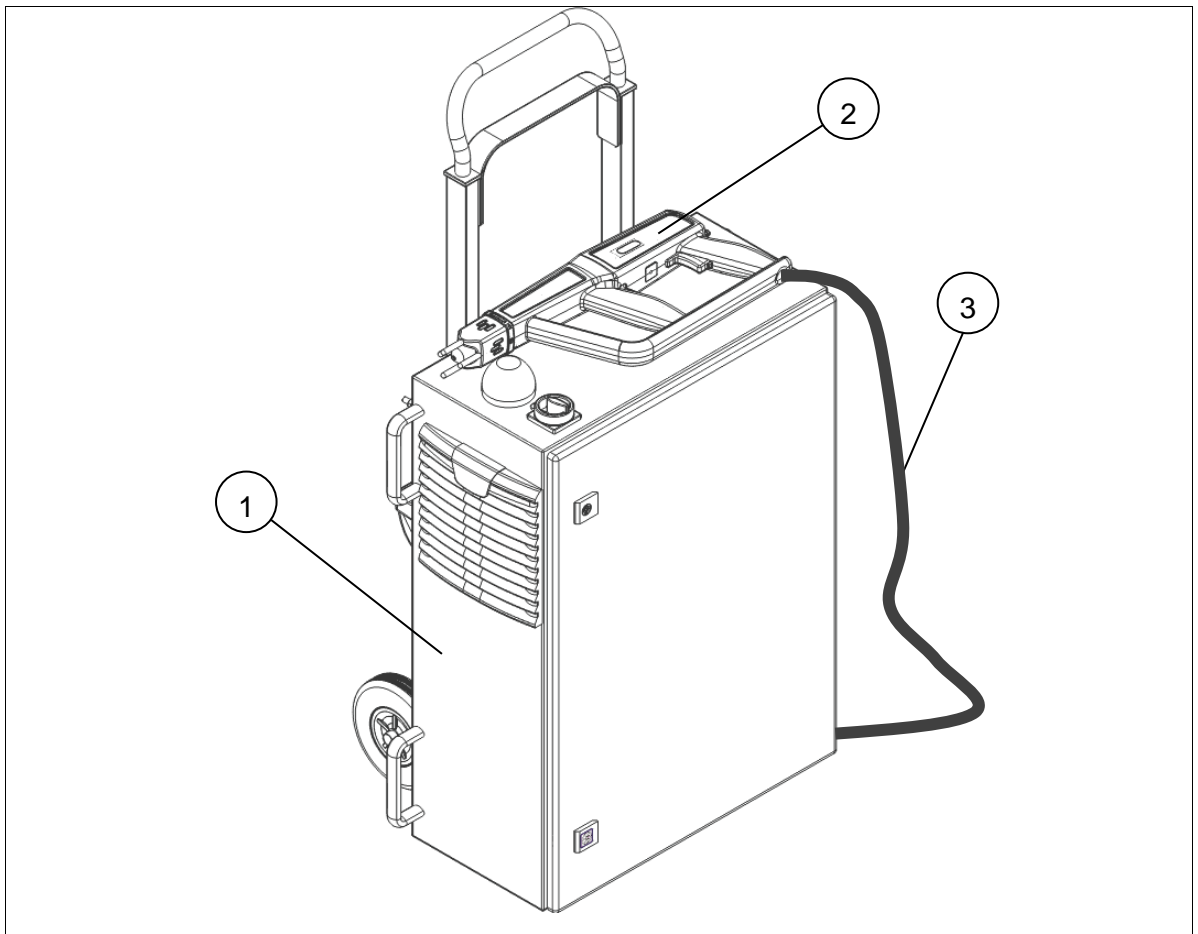

No.	Component
1	Maintenance for the stand-alone unit
2	Handheld device
3	Cable assembly
4	Mains connection cable (not pictured)

2.2.2 Stand-alone unit: Description and connections

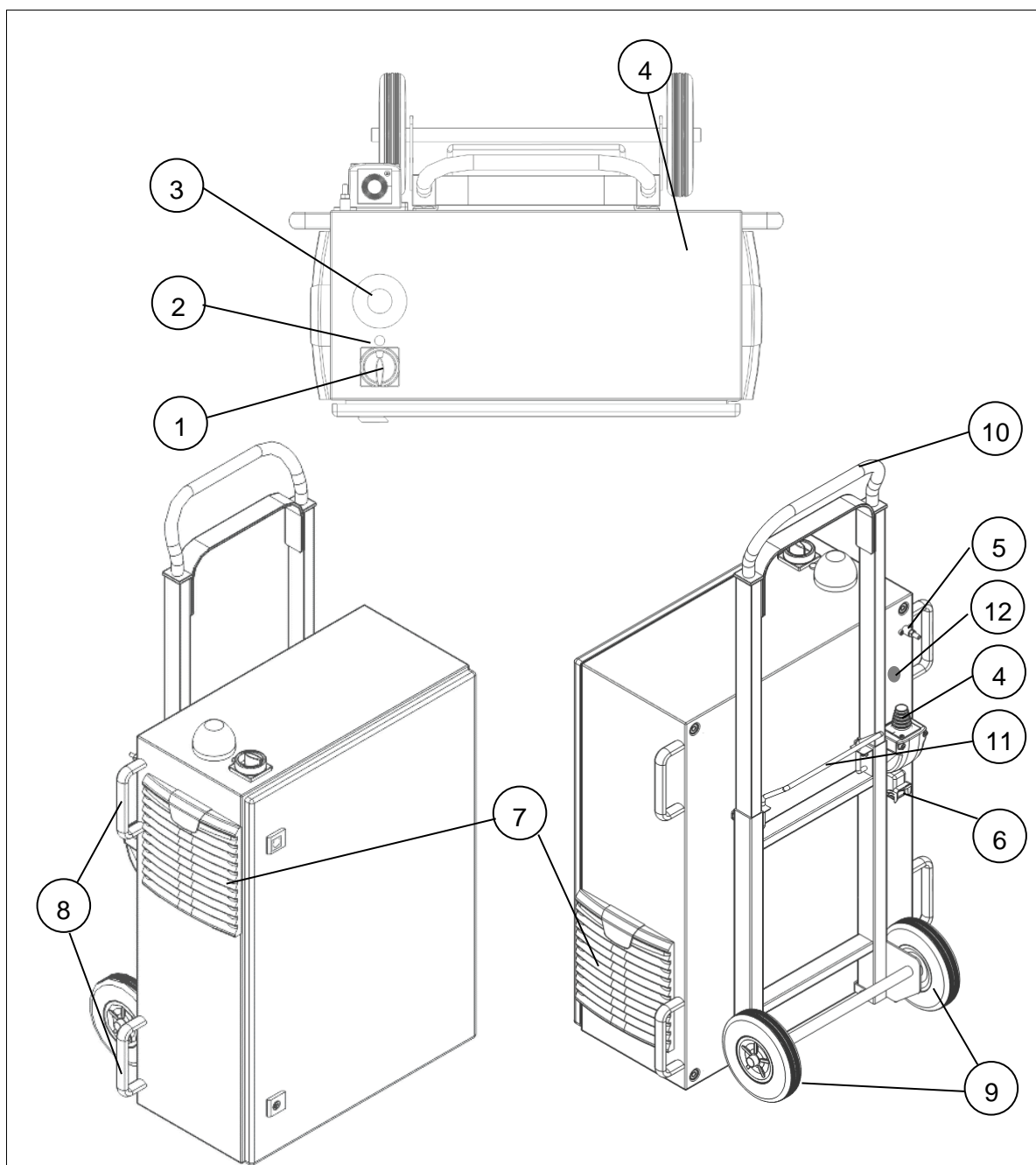

Fig.: Schematic diagram of the stand-alone unit (front view and top view)

No.	Component
1	Master switch I/O
2	Signal lamp for "machine on/off" (red)
3	Warning light for "machine is ready for operation" (yellow)
4	Cable assembly bushing
5	Functional grounding connection
6	Socket for the mains connection cable (with cover cap)
7	Fan grille
8	Carrying grips for transport
9	Castor wheels

10	Grip (pull-out) for rolling transport
11	Position lock for pull-out grip
12	Fuse F1 (see 3.1 Technical data)

2.2.3 Handheld device: Description

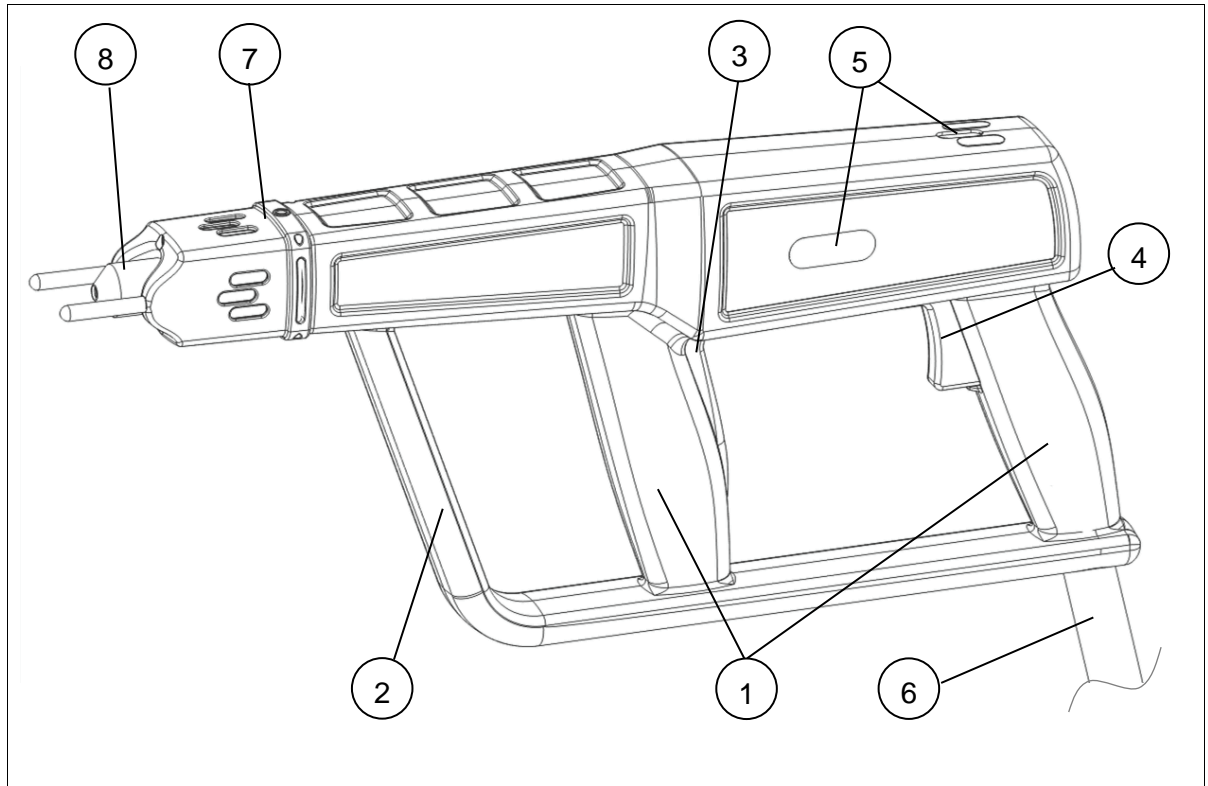

Fig.: Schematic diagram of the handheld device

No.	Component
1	Handle
2	Protective bar
3	“Start stand-alone unit” button
4	“Start plasma generation” button
5	“Stand-alone unit ready” signal light
6	Cable assembly
7	Spacer
8	Plasma nozzle

2.3 Scope of delivery

The scope of delivery includes the following components:

- Plasma tool machine (consisting of the stand-alone unit and the handheld device with spacer)
- Mains connection cable
- Operating instructions

3

Technical data

3.1

Technical data

Description	Value
Electrical data	
Electrical connection	220 V – 240 V AC / 50 Hz / max. 6 A
Mains fuse	F1 = 10 A / 250 V AC / time lag
Power consumption	≤ 1500 W
Protection	Stand-alone unit: IP 54 handheld device: IP 23 (in accordance with EN 60529)
Protection class	Class I acc. to IEC 61140
Operating voltage of plasma generator	<ul style="list-style-type: none">• up to 20 kV U_{peak} (max. voltage for ignition (briefly))• up to 2 kV RMS (average operating voltage)
Activation period	50% ED S2 20 minutes
Dimensions	
Weight	56 kg; 123.5 lbs
Dimensions	610 x 780(1070) x 430 mm; 24.0 x 30.7(42.1) x 16.9" (width x height x depth)
Cable assembly	
Cable length	5 m
<ul style="list-style-type: none">• Minimum cable bending radius	150 mm (5.9")
<ul style="list-style-type: none">• Maximum cable extension torsion	± 90°/m
Operating conditions	
Air humidity	< 80% rel. (non-condensing)
Temperature	0– 40°C; 32 – 104°F
Storage conditions	
Air humidity	< 80% rel. (non-condensing)
Temperature	0 – 60 °C; 32 – 140 °F
Noise emissions	
<ul style="list-style-type: none">• Sound level	< 60 dB(A) at 1 metre away

4 Transport/storage

4.1 Storage

- Store the machine in a dry place. This will prevent the electrical contacts from corroding.
- Protect the machine from dirt and foreign objects.

4.2 Transport

The machine is equipped with a trolley for changing location to a hard, level underfloor. To move the machine, please carry out the following steps:

- Ensure that the machine is switched off, disconnected from the power supply and cooled down. Check that all moving parts are in a stable, fixed position so that while moving the machine, these parts do not fall off.
- Bring the trolley grip to the upper position, by pressing the position lock and pulling the grip upwards until it is solidly engaged.
- Carefully tip the machine back, using the trolley grip, so that the machine is standing on its wheels.
- You may now move the machine.
- **ATTENTION:** Do not pass the trolley over inclined floors and do not use the trolley to lift the machine or to transport the machine over stairs.

After the change of location is concluded, make sure that the machine is positioned at a suitable spot, and that it is stable and secure.

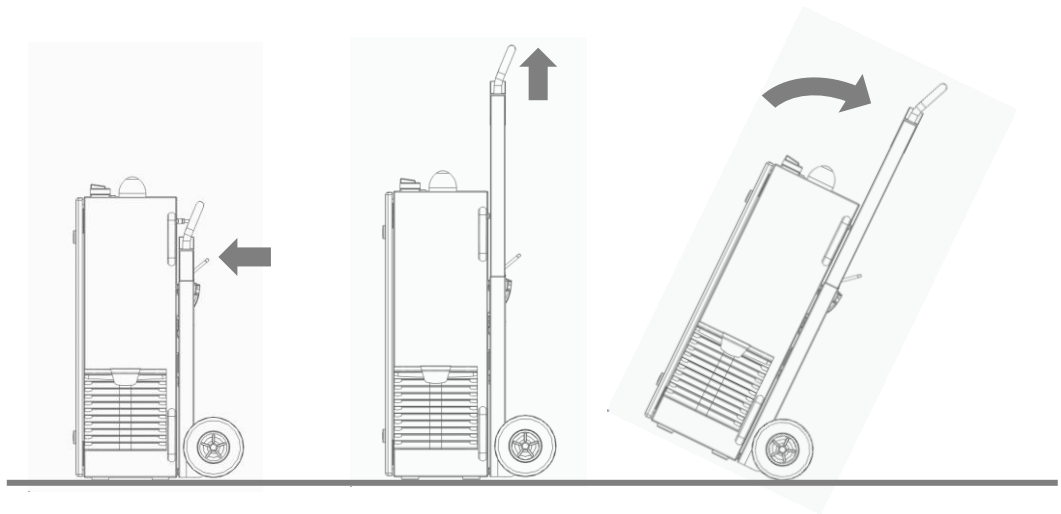

If you need to move the machine over non-level ground or over stairs, please proceed as follows:

- Ensure that the machine is switched off, disconnected from the power supply and cooled down. Check that all moving parts are in a stable, fixed position so that while moving the machine, these parts do not fall off.
- Bring the trolley grip to the lower position, by pressing the position lock and pushing the grip downwards until it is solidly engaged.
- Carefully tip the machine using the castor wheels until it is level.
- Only carry the machine with a second person.
- Only use the fixed carrying handles on both sides of the machine for carrying it.

After the change of location is concluded, make sure that the machine is positioned at a suitable spot, and that it is stable and secure.

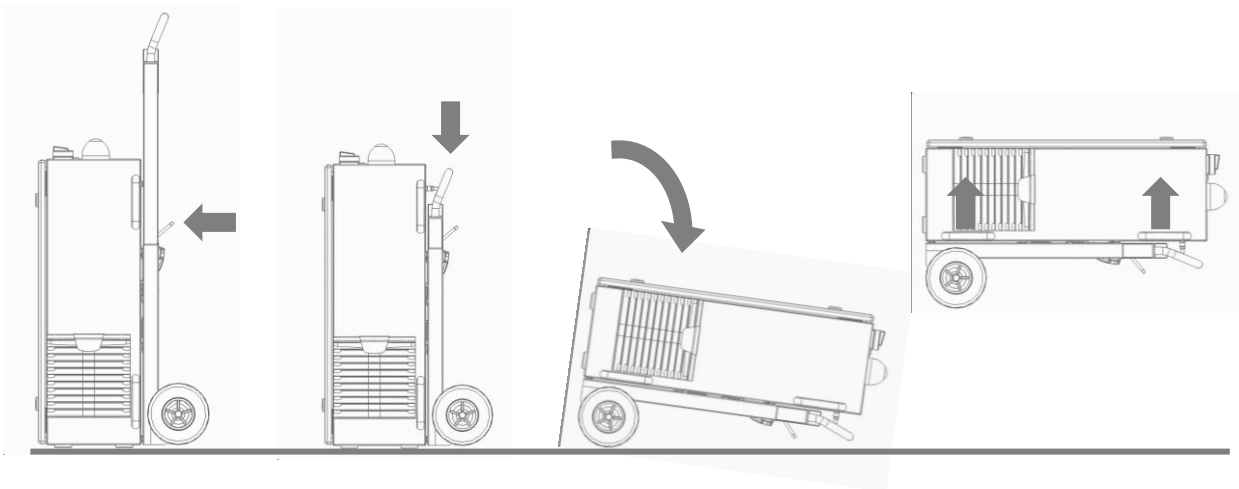

Attention – damage to machine!

- The machine can become damaged if you attempt to move the stand-alone unit by pulling on one of the cables. Always ensure that there is no nominal tensile stress on the cables. The cable assembly can also become damaged by kinking or by a bending radius that is too tight. Do not kink the cable assembly and adhere to the minimally-permitted bending radius in accordance with the “Technical Data” Chapter (page 10).
- A ceramic component is built into the handle. This can become damaged in the event of hard impacts or falls, and can cause damage to the machine. Always ensure that the handle is secured against impacts and falls during transport.

5 Unpacking and installation



Caution – electrical voltage!

Danger: 230 V and high voltage.

- The entire machine must not be opened. Both the handheld device and the stand-alone unit are sealed by the manufacturer. In the event of damage to the seal, the warranty is voided.

5.1 Unpacking

- Carefully open the machine packaging. Note the information about directions provided on the packaging.
- Take the machine out of the packaging.
- After taking the machine out of the packaging, check it and all cables for damage.

5.2 Installation requirements

Before installing the machine, the following points must be met:

- The machine must be fully intact.
- The machine may only be connected using the provided power cable.
- The machine's main switch is to be used as an all-pole separator.

5.2.1 Installation and start-up

The stand-alone unit may only be operated while in an upright position. Ensure that a sufficient distance is provided (>150mm) for the ventilation slots.

To install the machine, perform the following steps in the specified order:

1. Place the machine on a hard, level floor and make sure that the machine is stable.
 - Ensure that a distance of at least 150 mm is maintained between all ventilation slots and other objects.
 - Make sure that the installation location is chosen so that no nominal tensile stress is placed on the cables and lines when using the machine.
2. Open the cover on the machine for the mains connection and connect the mains connection cable to the machine.
3. Plug the mains connection cable into a suitable power outlet with earthing pins.

If in doubt, check if the protective earth contact of the power outlet is functional.

- ✓ The machine is installed.

5.2.2 Using the spacer

There is a spacer located at the front end of the handheld device. For one thing, this serves to ensure a constant distance to the substrate, and for another, this protects the nozzle from contact, since it can heat up to 200°C during operation.



Caution – Hot surface!

The area around the plasma generator nozzle may reach temperatures of up to 200 °C.

- Wait until the machine has cooled down if you need to touch this area.
- After use, store the machine only in places that are not temperature-sensitive or are not combustible.

Putting on and taking off the spacer (e.g. For replacing nozzles/electrodes)

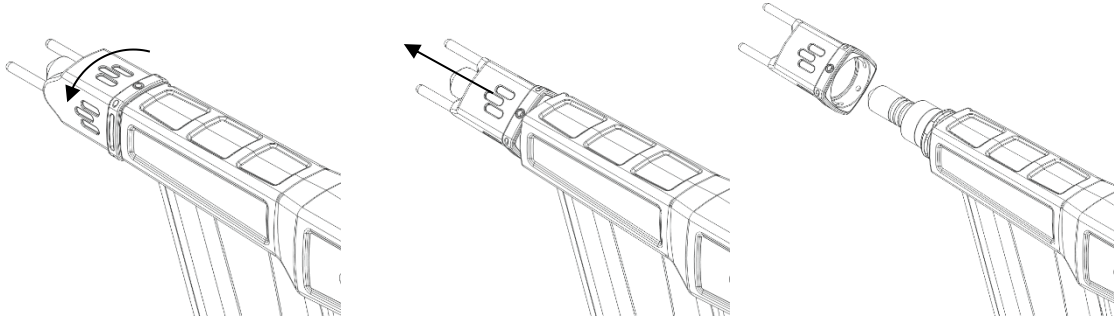

To take the spacer off the machine, rotate it until it is positioned at a 45° angle and pull it to the front and off of the machine.

To put the spacer on, push it into a 45° position on the machine until it snaps in. Afterwards, rotate it by 45° in one of the four lock positions.

Changing the working distance

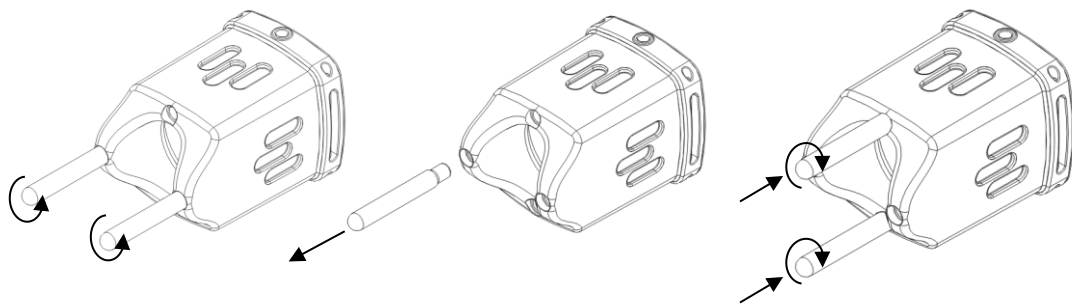

The two uprights in the spacer can be screwed into two further lower positions by unscrewing them. This adjusts to a shorter working distance and thus produces a more intensive plasma treatment for the same treatment time. Attention: Here, the temperature loading in the substrate is also higher.

Adjustment of the spacer to the work flow direction

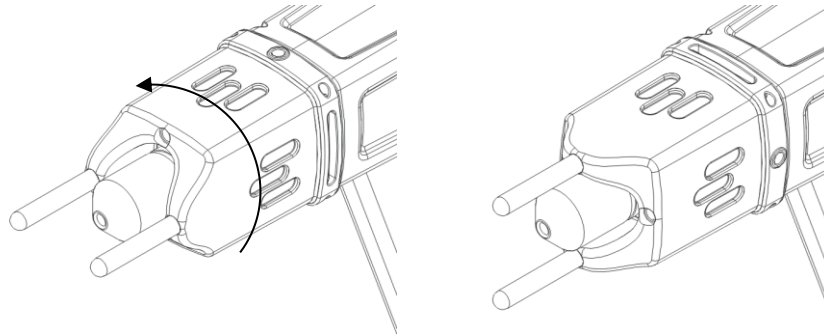

To adjust the spacer to the work flow direction, you can rotate it in 90° increments. The spacer engages in these positions.

Change the spacer upright (e.g. in the event of breakage or replacement)

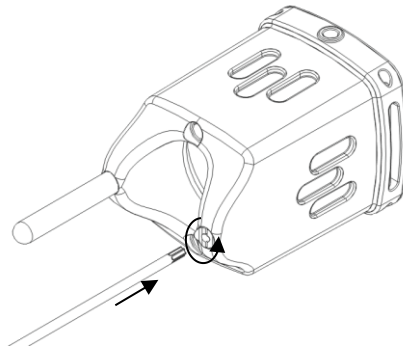

The uprights can be screwed in and unscrewed by hand.

If an upright should break, this will expose a hole in the thread. The remaining threaded portion in the spacer may, for example, be removed with a small hexalobular screwdriver.

6 Special note on the operation of the plasma process

6.1 General description

Treating surfaces with atmospheric plasma has several advantages. Examples include the increase of surface energy by an improved generation of surface wetting.

An optimal surface wetting is the first and often decisive step to get a good imprint, a uniform coating, a consistent coat of lacquer or an integrally-bonded adhesive application. The bond at this boundary layer often determines the longevity and adhesive strength of this material pairing.

Atmospheric-pressure plasma increases throughput in many industrial processes, while at the same time saving costs for solvents or chemical primers. We have successfully integrated our plasma products into the following application fields:

- Cleaning of metal, glass and plastics
- Surface activation and surface functionalisation for optimised wettability
- Coating for new surface properties
- Plasma-assisted laminating process
- Plasma-assisted adhesive bonded joints
- Plugging and sealing
- Plasma induced reduction of metal surfaces
- Chemical-free bleaching of textiles
- Plasma sterilisation of fabric
- Handling of food products for quality and shelf life
- Sterilisation of thermally-unstable plastics
- Multi-component injection moulding

Practically all technical material classes can be efficiently processed under atmospheric pressure:

- Metals, metal alloys
- Plastics and composite materials
- Glass, ceramics, inorganic composites, natural stone
- Real leather, imitation leather
- Natural fibres, wood, paper

Since the plasma treatment is always just a single part of the entire process, it is important that the additional influencing quantities are known in order to achieve an optimal result.

Typical influencing quantities could be:

- Plasma process: Distance to the substrate, speed, nozzle geometry
- Substrate/ workpiece: Material composition, contamination, electrical conductivity, thermal conductivity, moisture content
- Workpiece treatment: Contamination before or after the plasma process, the time duration between the plasma process and the follow-up process

Treatment examples can be requested directly from **Relyon Plasma GmbH**.

Additional information on applications, as well as publications, can be found on the website www.relyon-plasma.com.

6.2 Notes on the correct handling of the substrates to be treated



Caution – electrical voltage!

- Danger from high voltage
 - Never direct the plasma beam at people or animals.
 - Never touch the plasma nozzle or the plasma jet when the machine is in operation.
 - Never touch the workpiece to be treated or its holder during plasma generation.
 - Make sure that no third party comes into contact with the workpiece to be treated or its holder.
 - If electrically conductive materials touch the workpiece to be worked on, these materials must be grounded.

Since the machine operates with high voltage, certain safety precautions must be met. This applies not only to direct handling of the machine, but also to the workpiece to be handled and its holder.

In general, the workpiece holder and all other objects that the workpiece comes into contact with must be earthed. The possibility must be completely excluded, for example, of the user or a third party making contact with the workpiece holder (made from conductive material) during plasma treatment. It is also possible that a third party could receive an electrical shock from the workpiece through the workpiece holder.

If a holder made from insulating material is used, it must have a dielectric strength of at least 20 kV.

A functional grounding connection is provided on the machine for a special form of plasma treatment involving transferred electric arcs. If you want to use this special application, please contact **Relyon Plasma GmbH** directly.

6.3 Carrying out surface treatment

Depending on the type and condition of your substrate, pre-cleaning before the plasma process can improve the overall outcome.

The effect of the treatment depends on the working distance, treatment time, speed and consistency of movement as well as the material to be treated.

Ensure that the substrate is not thermally damaged due to movement that is too slow or a working distance that is too low.

Treatment examples can be requested directly from **Relyon Plasma GmbH**.

6.4 Measures to take after the surface treatment

To achieve an optimal result, it is important that as little time as possible elapse after the plasma treatment and that the treated surface is not touched or contaminated. Cleaning the surface **AFTER** the plasma treatment is not recommended. Since the workpiece can heat up depending on the type and duration of the plasma process, it may be necessary to allow the workpiece to first cool down before the next process step is executed in order to not negatively affect the process through the introduction of heat (e.g. in certain bonding processes).



Caution – Hot surface!

The workpiece to be treated can become heated up by the plasma process depending on the process parameters. If necessary, allow the workpiece to cool down before handling it.

7

Operation

7.1

Controls / displays



Caution – electrical voltage!

Danger of electric shock.

- Never reach into the area around the connected plasma generator while it is running or if it has shut down (e.g. to check why the plasma generator has shut down).

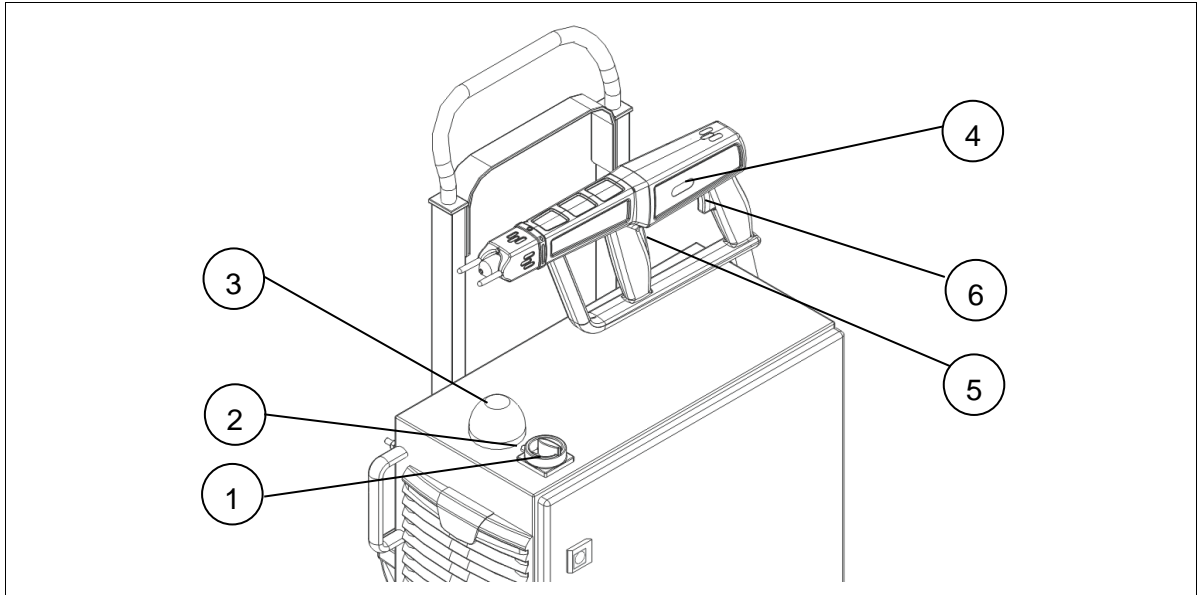

No.	Description	Function
1	Master switch	Switches the power supply voltage on/off
2	Power on (red)	Displays: Power supply is established, master switch is switched on
3	Warning light (yellow)	Displays: -flashing: Currently in warm-up time, it is expected to be ready for operation shortly -lit continuously: Machine is ready for operation, assume it to be in plasma operation/supplied with high voltage
4	Handheld device ready (violet)	Displays: -flashing: Currently in warm-up time, it is expected to be ready for operation shortly -lit continuously: Machine is ready for operation, assume it to be in plasma operation/supplied with high voltage
5	“Start stand-alone unit” button	Starts the warm-up time in pressed position
6	“Start plasma generation” button	When ready for operation, this starts the plasma generation

7.2 Switching on and operating the machine



Attention – damage to machine!

- The machine can become damaged if you attempt to move the stand-alone unit by pulling on one of the cables. Always ensure that there is no nominal tensile stress on the cables.
The cable assembly can also become damaged by kinking or by a bending radius that is too tight. Do not kink the cable assembly and adhere to the minimally-permitted bending radius in accordance with the “Technical Data” Chapter (page 10).
- A ceramic component is built into the handle. This can become damaged in the event of hard impacts or falls, and can cause damage to the machine. Always ensure that the handle is secured against impacts and falls during transport.
- The machine is classified with a S2 50% switch-on time of 20 minutes. In continuous operation, operate the machine for no longer than 10 minutes, and afterwards allow the machine to cool for at least 10 minutes. Even in the event of shorter operation intervals, a similar cooling-off time must be observed to rule out the possibility of equipment damage.
- When the front lock button is released, the compressor and the fan in the stand-alone unit continue to run for approx. 1 minute to cool down the machine. During this follow-up time, never switch off the machine at the master switch and do not disconnect the power supply. This could cause damage to the machine.

To switch the machine on, perform the following steps in the specified order:

1. Switch machine on using master switch (#1).
 - The lamp (#2) next to the machine's main switch lights up.
 2. Hold the handheld device with both hands on the provided grips and place it in a safe area.
 3. Press and hold the front handle button (#5) on the handheld device. The warning lamp (#3) and the ready lamp (#4) start to flash, the compressor in the stand-alone unit is enabled and gas flow is audible from the nozzle. After approx. 8 seconds the ready lamp on the hand part and the warning lamp on the stand-alone unit light up steadily. The machine is now ready for operation. Press and hold down the front handle button (#5) until taking a long break or other interruption to your work.
 4. Now, press and hold the rear button (#6) of the handheld device to begin the plasma generation.
To interrupt the plasma generation only for a brief period of time, release only the rear button. As such, the readiness of the handheld device is maintained without the need to start a new warm-up time. Observe the switch-on time in accordance with the technical data (see page 10).
- ✓ The machine is switched on.

7.3 Switching off the machine



Caution – Hot surface!

The area around the plasma generator nozzle may reach temperatures of up to 200 °C.

- Wait until the machine has cooled down if you need to touch this area.
- After use, store the machine only in places that are not temperature-sensitive or are not combustible.

To switch off, perform the following steps in the order given:

1. Switch off the plasma generation by letting go of both buttons (#5, #6) on the handheld device and place the handheld device in a safe location.
 2. Wait until the fan and compressor after-run of approx. 1 minute have ended.
 3. Switch off the stand-alone unit by toggling the master switch (#1) to position “O”.
- ✓ The machine is switched off.



Attention – damage to machine!

When the front lock button is released, the compressor and the fan in the stand-alone unit continue to run for approx. 1 minute to cool down the machine. During this follow-up time, never switch the master switch off and do not disconnect the power supply. This could cause damage to the machine.

8 Taking out of service

To take the machine out of service, perform in the following steps in the order given:

1. Switch machine off using master switch (#1).
 2. Disconnect the machine from the mains voltage supply: Disconnect the power connector.
 3. Close the mains connection socket on the stand-alone unit with the cover cap.
- ✓ The machine is out of service.

9 Cleaning and maintenance



Caution – High voltage! Danger of death!

High voltage is produced in the interior of the machine. This voltage is still present after the machine is switched off.

- It is forbidden to open the machine.
- Before carrying out maintenance or repair work, always disconnect the machine from the power supply.



Attention – damage to machine!

Opening the machine may cause it to be damaged.

- It is forbidden to open the machine.

9.1 Cleaning

Only clean the outside of the machine.

- The machine must be cooled down, switched off and disconnected from the mains voltage supply.
- Only clean the machine with a damp cloth.

9.2 Maintenance for the stand-alone unit

Replace the filter mats at least every 5000 operating hours. If working in environments with high levels of dust, they may have to be replaced sooner. You can source the filter mats needed as spare parts from **Relyon Plasma GmbH**.

To change the dust filters, proceed as follows:

1. Disconnect the power supply from the machine.
2. Open the filter holder by the tab with the logo.



3. Use a new filter mat

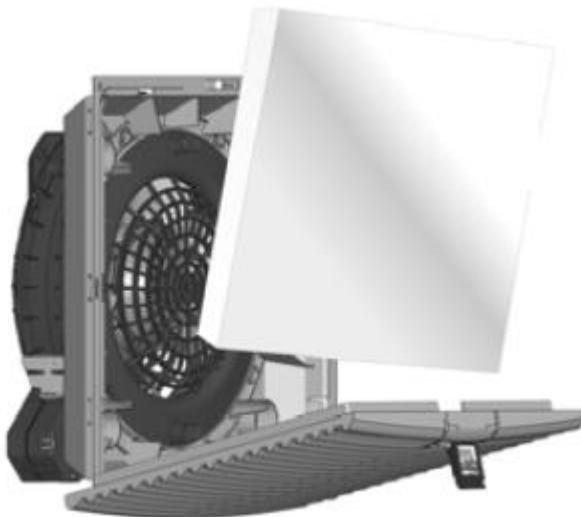

4. Press the filter holder by the tab until it noticeably clicks into place.

9.3 Maintenance for the hand part



Caution – Hot surface!

The area around the plasma generator nozzle may reach temperatures of up to 200 °C.

- Wait until the machine has cooled down if you need to touch this area.
- After use, store the machine only in places that are not temperature-sensitive or are not combustible.



Attention – damage to machine!

The cap nut is designed for tightening and loosening by hand. Do not use a tool to tighten or loosen the cap nut. This may damage the machine.

The handheld device contains the plasma nozzle and the inner electrode. These are subject to wear and tear depending on the duration of use, the environmental conditions and the process that was carried out.

A thick oxide layer on the plasma nozzle and a marked burnt-in crater on the electrode will impair the ignition properties and increase the temperature of the plasma flame. In these cases the parts must be replaced.

To enable access to the nozzle and electrode, remove the spacer in accordance with Chapter 5.2.2.

9.3.1 Replacing nozzles and electrodes

The replacement cycles of the nozzles and electrodes have been determined by reylon plasma in accordance with a standardised test. Deviations are possible, depending on application.

- Nozzles in operation with air: Approx. 500 hours
- Electrodes in operation with air: Approx. 1000 hours

Depending on application, considerable deviations from these mean values are possible.

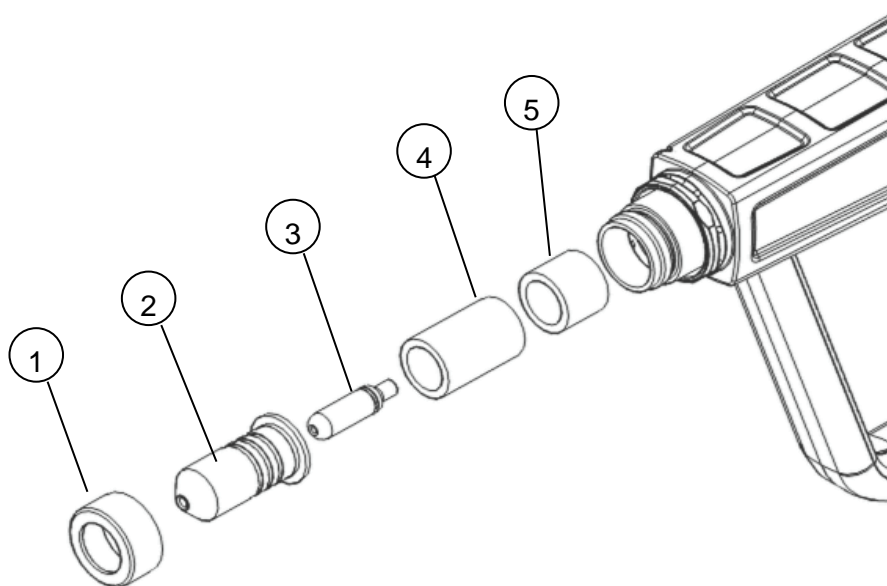

To replace the nozzle and electrode, carry out the following points:

1. Switch off the machine and wait until the plasma generator has cooled down.
 2. Unscrew the nozzle (2) with the cap nut (1) (right-handed thread).
Caution: When removing the nozzle, the ceramic sleeve (4) and the spacer for the ceramic sleeve can fall out of the generator housing (5)!
 3. Unscrew the electrode with O-ring (3) (right-hand thread) using an Allen key (SW 2.5 mm).
 4. Extract the electrode with O-ring (3) out of the coil by hand.
 5. Insert the new electrode with O-ring (3) by turning it into the coil and tightly screw it in with a torque wrench (tightening torque 1 Nm).
 6. If necessary, first install the spacer for the ceramic sleeve (plastic) and then install the ceramic sleeve (4) back into the generator housing (5).
Caution: Observe the correct sequence during installation!
 7. Screw the new nozzle (2) with the cap nut (1) to the generator housing (5) again and tighten it hand-tight.
- ✓ The nozzle and electrode are now replaced.



Attention: Barrier sleeve made from ceramics in the plasma generator!

1. Barrier sleeves (#4 and #5) are inserted into the plasma generator.
2. Ensure that these barrier sleeves are inserted in the correct sequence. Absent or incorrectly inserted barrier sleeves lead to destruction of the plasma generator.
3. The barrier sleeve (#4) is made of ceramics – Caution, risk of breakage!

10 Troubleshooting

10.1 Overview of faults / errors

Fault / error	Cause	Rectification
Master switch (#1) does not light up	Fuse defective.	Fuse on the rear side of the machine must be changed.
	Power connector incorrectly connected.	Check the mains unit connection.
	No / incorrect voltage supply.	Check the mains voltage supply.
No plasma is being generated	There is an error, the machine is not ready.	Ensure that both switches are pressed down and that the warm-up time (flashing warning lamp) is up (continuous light).
		De-energise the machine. Switch on again.
		Problem cannot be fixed: Contact customer service.
Parasitic discharge (discharge at undesired points, e.g. at plasma generator cable connector)	Machine or high-voltage cable damaged	Take the machine out of operation and contact customer service.
Damage from flashover (e.g. to machine parts)	Faulty earth connection	Check that all earth connections have been established correctly.

10.2 Customer service

If the machine is not working properly, contact **Relyon Plasma GmbH**.

You will find the contact information at the end of the operating instructions.

11 Environment

11.1 Disposal



Be mindful of the environment.

Used electrical and electronic equipment must not be disposed of along with normal waste.

- The machine contains valuable materials that can be recycled. Take the machine to a suitable collection point.

12 Conformity / standards

12.1 CE



We declare that this product conforms to CE standards.

The product name can be found on the name plate of the machine's housing.

12.2 Product standards

The machine satisfies the following requirements and standards:

2014/30/EU EC-EMC guideline Guideline 2014/30/EU of the European Parliament and the Council Directive of 26 February 2014 for the harmonisation of the approximation of the laws of the Member States relating to electro-magnetic compatibility	
2014/35/EU EC Low Voltage Directive Guideline 2014/35/EU of the European Parliament and the Council Directive of 26 February 2014 for the harmonisation of the laws of the Member States relating to Electrical equipment for use within certain voltage limits in the market	
EN 61000-6-4:2007+A1:2011 emitted interference	
EN 61000-6-2 2005 immunity to interference	
EN 61000-3-2:2014 and EN:61000-3-3:2013 emitted interference	
EN 61010-1:2010 safety test	
EN 50581:2012 Restriction of Hazardous Substances (RoHS)	
Degree of protection IP23 or IP54	IEC 60529

13 Spare and wear parts

Item number	Description	Type
1000619200	Spacer with 2 uprights	Spare part
1000625400	Upright for spacer	Spare part
77071600	Spacer for ceramic sleeve	Spare part
74532300	Ceramic sleeve	Spare part
77071900	Cap nut	Spare part
76849401	PB3 electrode with O-ring	Wear part
1000242500	A250 nozzle	Wear part
1000600700	A350 nozzle	Wear part
78707200	A450 nozzle	Wear part

Relyon Plasma GmbH

Weidener Strasse 16
93057 Regensburg
Germany

Phone: +49-941-60098-0
Fax: +49-941-60098-100
E-mail: info@relyon-plasma.com
<http://www.relyon-plasma.com>